

A Powerful Hybrid *puc* Operon Promoter Tightly Regulated by Both IPTG and Low Oxygen Level

Zongli Hu[#], Zhiping Zhao[#], Yu Pan, Yun Tu, and Guoping Chen*

Key Laboratory of Biorheological Science and Technology and Bioengineering College, Chongqing University,
174 Shapingba Main Street, Chongqing 400044, People's Republic of China; fax: (0086) 23-6511-2674;
E-mail: chenguoping@cqu.edu.cn; huzongli@cqu.edu.cn; zhipingzhao@cqu.edu.cn; ipying@163.com; tuyun@cqu.edu.cn

Received September 8, 2009

Revision received November 5, 2009

Abstract—*Rhodobacter sphaeroides* has been intensively studied and provides an excellent model for studying both photosynthesis and membrane development. The photosynthetic apparatus (LH2 and LH1–RC complexes) can be synthesized in large scale and integrated into the intracytoplasmic membrane system under specific conditions, which thus provides us insight to utilize the *puc* or (and) *puf* operon to heterologously express recombinant proteins in the intracytoplasmic membrane using *Rb. sphaeroides* as a novel expression system. However, basal level of expression of *puc* and *puf* promoter is uncontrolled. We report the construction of LH2 polypeptide expression vector that contains a reengineered *lacI^q-puc* promoter–*lac operator* hybrid promoter, which allows the *puc* operon to be regulated by both IPTG and low oxygen level. Synthesis of LH2 complexes was completely repressed in the absence of isopropyl β-D-thiogalactoside (IPTG), and the degree of induction was controlled by varying the concentration of IPTG. The optimal concentration of IPTG was determined. SDS-PAGE and Western blot were employed for further analysis. Our results suggest that the reengineered hybrid promoter is efficient to tightly regulate the expression of the *puc* operon, and our strategy can open up a new approach in the study of the membrane protein expression system.

DOI: 10.1134/S0006297910040176

Key words: LH2, hybrid promoter, IPTG, *Rhodobacter sphaeroides*

Rhodobacter sphaeroides is a purple non-sulfur gram-negative facultative anaerobe capable of anoxygenic photosynthesis [1]. It has multiple growth models including aerobic and anaerobic respiration, fermentation, and anoxygenic photosynthesis [2]. It is also one of the most diverse subgroups of the α-3 subgroup of the *Proteobacteria* [3]. This bacterium can grow under both photoheterotrophic and chemoheterotrophic conditions. When growing chemoheterotrophically, *Rb. sphaeroides* has a typical gram-negative cell envelope structure and its growth is supported by aerobic respiration. When oxygen is removed from such a culture, a series of events is triggered which, through a process of invagination, results in the differentiation of the cytoplasmic membrane into specialized domains and the formation of the intracyto-

plasmic membrane (ICM) system, which houses the photosynthetic apparatus. The proliferation of this membrane provides an increased surface area for the absorption and utilization of light by the photosynthetic apparatus. The photosynthetic apparatus consists of three membrane-bound pigment–protein complexes. Light-harvesting complexes 1 and 2 (LH1 and LH2), which are the major pigment–protein complexes, have been designated B800–850 and B875 based on their near-infrared absorption maxima [4]. The third complex incorporates reaction center (RC) along with the associated components required for subsequent electron transport and energy transduction. The ratio of LH1 to RC is fixed at approximately 15 : 1, whereas the ratio of LH2 to the LH1–RC unit is variable, changing in a manner inverse to light intensity [5].

It has been well reported that LH2 and LH1 complexes are comprised of α- and β-polypeptide with highly symmetric arrangement, binding noncovalently bacteriochlorophylls and carotenoids, and are constructed in a remarkably similar fashion. However, RC is comprised

Abbreviations: ICM, intracytoplasmic membrane; IPTG, isopropyl β-D-thiogalactoside; LH1(2), light-harvesting complex 1(2); RC, reaction center.

[#] These authors contributed equally to this work.

* To whom correspondence should be addressed.

of three subunits with unsymmetrical arrangement, namely H, L, and M [6]. The LH2 complex from *Rb. sphaeroides* is a nonamer [7], like many other purple bacteria, such as *Rhodospseudomonas acidophila* and *Rhodovulum sulfidophilum* [8]. However, LH2 from *Rhodospirillum molischianum* is an octamer [9, 10]. In the nonamers, each unit contains one α/β polypeptide, the nine α -polypeptides form a hollow cylinder with the nine β -polypeptides arranged outside. LH2 β -polypeptide and α -polypeptide of *Rb. sphaeroides* are encoded by the *pucB* and *pucA*, respectively. It has been well-documented that photosynthesis genes including *bch*, *crt*, *pucBA*, *pufBA*, *pufLM*, *pufA*, etc. are tightly regulated by oxygen tension and light intensity with uncertain mechanisms. Oxygen can shut down the synthesis of photosynthetic apparatus very rapidly. Similarly, photosynthesis genes are also regulated inversely to the incident light intensity [11].

Rhodobacter sphaeroides is the best-characterized purple bacterium and provides an ideal model system for studying both photosynthesis and membrane development [2]. Additionally, LH2 and LH1–RC complexes account for a major portion of the ICM, and they can be synthesized in large scale and then integrated into the ICM system under anaerobic conditions. These provide us insight to utilize the *puc* or (and) *puf* operon to heterologously express recombinant proteins in ICM using *Rb. sphaeroides* as a novel expression system. As we have described above, photosynthesis genes are regulated by oxygen tension. Unfortunately, in many cases the LH2 and LH1–RC complexes can still be synthesized at basal level even in the presence of oxygen. This property can be particularly troublesome when utilize the *puc* or (and) *puf* operon to express recombinant proteins or other gene products that are toxic to the cell using *Rb. sphaeroides* as a platform. Experiments requiring strong repression and precise control of cloned genes can be difficult to conduct because of the relatively high basal level of expression of currently employed promoters [12], such as *puc* and *puf* promoter of *Rb. sphaeroides* [13]. However, vast numbers of strong hybrid promoters as well as some of their derivatives have been constructed and widely applied for expression of genes of interest typically based on the *E. coli lac* operon [14], which provides us clear insight to construct a hybrid promoter to regulate the expression of a gene of interest in *Rb. sphaeroides*. LacI repressor is one of the best-studied prokaryotic transcriptional regulatory proteins, which can bind to *lac* operator (*lacO*) and prevent the RNA polymerase from transcribing three structural genes – *lacZ*, *lacY*, and *lacA*. The *puc* operon of *Rb. sphaeroides* consists of the *puc* promoter, *pucBA* genes encoding LH2 β - and α -polypeptides, respectively, and downstream *pucC* gene helping to assemble the LH2 complexes into ICM. Here we construct an LH2 polypeptide expression vector with a powerful hybrid *lacI*^q-*puc* promoter-*lac* operator allowing dual regulation by

both isopropyl β -D-thiogalactoside (IPTG) and low oxygen level.

MATERIALS AND METHODS

Bacterial strains, plasmids, and growth conditions.

Strains and plasmids used in this study are listed in the table. *Rhodobacter sphaeroides* strains were grown at 34°C in M22+ medium supplemented with 0.1% casamino acids for growth in liquid culture [20]. Growth under low oxygen tension was performed by incubating 750 ml of culture in 1-liter flasks under gentle agitation. For aerobic cultivation, 200 ml cultures were vigorously shaken in 1-liter flasks.

Escherichia coli strains were grown aerobically at 37°C in Luria–Bertani (LB) medium. Antibiotics were added to the growth media at the following concentrations: ampicillin, 100 $\mu\text{g/ml}$ for *E. coli*; tetracycline, 10 $\mu\text{g/ml}$ for *E. coli* and 1 $\mu\text{g/ml}$ for *Rb. sphaeroides*; neomycin, 20 $\mu\text{g/ml}$ for *Rb. sphaeroides*; streptomycin, 5 $\mu\text{g/ml}$ for *Rb. sphaeroides*.

Constructions of plasmid vectors. PCRs were carried out using PrimeSTARTM HS DNA polymerase from TAKARA. Primers used in this study are listed in the table. All amplified fragments were ligated into the pUC19 cloning vector and sequenced. For the construction of pRK*lacI*^q*pucPpucBHis*₁₀*AC* expression vector, PCR product containing *lacI*^q amplified from *E. coli* JM109 was cut from pUC19-*lacI*^q with *EcoRI* and *SacI* and ligated into the pRK415 vector cut with the same restriction enzymes, producing plasmid pRK-*lacI*. Then the PCR product containing the *pucP* promoter and *lacO* was removed from pUC19-*pucP-lacO* vector digested with *XhoI* and *KpnI* and ligated into pRK-*lacI* between the *XhoI* and *KpnI* sites, producing plasmid pRK-PO. After that, PCR product containing SD sequence, *pucB*, and Xa factor protease recognition site was cut from pUC19-SD-*pucB-Xa* with *KpnI* and *XbaI* and subsequently ligated into the pRK-PO vector digested with the same restriction enzymes, producing plasmid pRK-BXa. Finally, PCR product containing His₁₀-tag, *pucA*, *pucC*, and terminator was removed from pUC19-His₁₀-*pucA-pucC*-terminator vector and ligated into the pRK-BXa vector, both vectors digested with *XbaI* and *PstI*, producing plasmid pRK*lacI*^q*pucPpucBHis*₁₀*AC*. Plasmid pRK*pucPpucBHis*₁₀*AC* was constructed in a similar way.

Conjugation techniques. Plasmid DNA was mobilized into *Rb. sphaeroides* by using *E. coli* S17-1 as the donor as described previously [20]. Transconjugants were grown aerobically in the dark on plates of M22+ medium supplemented with appropriate antibiotics as described above.

Spectroscopy. Spectra of whole cells were recorded on a Perkin Elmer lambda 900 UV/VIS spectrometer (USA). A suitable blank of growth medium was used in each case.

Bacterial strains and plasmids used in this study

Strain or plasmid	Relevant characteristic(s)	Reference
<i>Rb. sphaeroides</i>		
<i>Rb. sphaeroides</i> NCIB8253	Wild type	R. A. Niederman (personal communication)
DD13	Genomic deletion of <i>pufBALMX</i> and <i>pucBA</i> , insertion of Nm^r and Sm^r gene	[15]
DD13/pRK <i>pucPpucBHis₁₀AC</i>	Containing plasmid of pRK <i>pucPpucBHis₁₀AC</i>	this work
DD13/pRK <i>lacI^qpucPpucBHis₁₀AC</i>	Containing plasmid of pRK <i>lacI^qpucPpucBHis₁₀AC</i>	—"
<i>E. coli</i>		
DH5 α	Strain used for cloning	[16]
S17-1	Tra+ strain used for plasmid mobilization	[17]
Plasmid		
pUC19	Cloning vector, Amp ^r	[18]
pUC19- <i>lacI^q</i>	pUC19 cloning vector containing <i>lacI^q</i>	this work
pUC19- <i>pucP-lacO</i>	pUC19 cloning vector containing <i>pucP</i> promoter and <i>lacO</i>	—"
pUC19- <i>pucP</i>	pUC19 cloning vector containing <i>pucP</i> promoter	—"
pUC19-SD- <i>pucB-Xa</i>	pUC19 cloning vector containing SD sequence, <i>pucB</i> and Xa factor	—"
pUC19-His ₁₀ - <i>pucA-pucC-terminator</i>	pUC19 cloning vector containing His ₁₀ -tag, <i>pucA</i> , <i>pucC</i> and terminator	—"
pRK415	Mob+, Tc ^r , vector	[19]
pRK- <i>lacI^q</i>	pRK415 derivative, expression vector containing <i>lacI^q</i>	this work
pRK-PO	pRK415 derivative, expression vector containing <i>lacI^q</i> , <i>pucP</i> promoter and <i>lacO</i>	—"
pRK-BXa	pRK415 derivative, expression vector containing <i>lacI^q</i> , <i>pucP</i> promoter, SD sequence, <i>pucB</i> and Xa factor	—"
pRK <i>lacI^qpucPpucBHis₁₀AC</i>	pRK415 derivative, expression vector containing <i>lacI^q</i> , <i>pucP</i> promoter, SD sequence, <i>pucB</i> , Xa factor, His ₁₀ -tag, <i>pucA</i> , <i>pucC</i> and terminator	—"
pRK <i>pucP</i>	pRK415 derivative, expression vector containing <i>pucP</i> promoter	—"
pRK <i>pucP</i> -BXa	pRK415 derivative, expression vector containing <i>pucP</i> promoter, SD sequence, <i>pucB</i> and Xa factor	—"
pRK <i>pucPpucBHis₁₀AC</i>	pRK415 derivative, expression vector containing <i>pucP</i> promoter, SD sequence, <i>pucB</i> , Xa factor, <i>pucA</i> , <i>pucC</i> and terminator	—"

Primer sequence

lacI^qF: 5'-CTCTGAGCTCGAGGACACCATCG AATGGTGC-3'

lacI^qR: 5'-CTCTGAATTCTAATTGCGTTGCGCTCACTG-3'

Cloned *lacI^q*

pucP-lacO^F: 5'-ATATGGATCCTCGAGGCCTCGGA CACCCTCGTT TTTGC-3'

pucP-lacO^R: 5'-CTCTGGTACCTGTGTGAAATTGTTATCCGCTCACAATCCACACATTATGGGTGTAC-3' Cloned *pucP-lacO*

pucP^F: 5'-ATATGGATCCTCGAGGCCTCGGACACCCTCGTTTTTGC-3'

pucP^R: 5'-CTCTGGTACCCATTATGGGTGTAC-3'

Cloned *pucP*

SD-*pucB*-XaF: 5'-ATATGGTACCAGTTGGGAGACGACACAGTGACTG-3'

SD-*pucB*-XaR: 5'-ATATTCTAGAGAGCTCCCTTCCCTCGATGCCGAGCCACGGGGTC-3'

Cloned SD-*pucB*-Xa factor

pucACF: 5'-ATATTCTAGACACCACCACCACCACCACCACCACCACCACCCTAA-

GTCGACGGATCTACTAGTCAGGAGAAGACTGACATGAC-3'

pucACR: 5'-ATATCTGCAGCAGTGGCAGGCAGGTGCTGCCTAG-3'

Cloned His₁₀-tag, *pucA*, *pucC* and terminator

Expression of LH2 complexes. Cell cultures were shifted from aerobic conditions to semi-aerobic conditions at A_{600} of 0.5–0.8, and continued incubation for about 8 h after adding IPTG.

Protein purification and Western blot analysis. Cells were resuspended in 20 mM Tris buffer (pH 8.0) in the presence of 100 mM NaCl and 1 mM phenylmethylsulfonyl fluoride and subsequently broken by three passages through a high-pressure homogenizer (Italy) at 1200 bar. Membranes were resuspended with 1.0% (v/v) lauryldimethylamine *N*-oxide and purified by Ni-IDA. For Western blot analysis, proteins were separated on 15–20% SDS-PAGE gradient gel and transferred to PVDF membrane. Anti-His antibody and goat anti-rabbit IgG-alkaline phosphatase were used as primary and secondary antibody, respectively.

RESULTS

Constructions of expression vectors. The resulting expression vectors were termed pRK*lacI^qpucPpucBHis₁₀AC* and pRK*pucPpucBHis₁₀AC*, as shown in Fig. 1. Both expression vectors are based on pRK415, which is a broad-range host plasmid. Figure 1a represents the construction of pRK*lacI^qpucPpucBHis₁₀AC* expression vector containing the powerful hybrid promoter. Construction of pRK*pucPpucBHis₁₀AC* carrying native promoter *pucP* only is depicted in Fig. 1b. Genes encoding LH2 complexes in pRK*lacI^qpucPpucBHis₁₀AC* can be expressed under the tight control of the hybrid promoter. The β - and α -polypeptide encoded by *pucB* and *pucA* will be integrated into the ICM by *pucC* encoding protein in both DD13/pRK*lacI^qpucPpucBHis₁₀AC* and DD13/pRK*pucP-*

pucBHis₁₀AC strains. Because of the introduction of the *lacI^q* and *lacO* into *pucP* promoter, respective inducer should be taken into account to derepress the *LacI^q* repressor protein when the *puc* operon is expressed. Apparently, genes of interest could be inserted into both vectors at the *SacI* and *XbaI* sites to construct recombinant proteins, which will be expressed, then integrated into the ICM following the native membrane protein under the control of *pucC* encoding protein. There is a Xa factor protease recognition sequence and a His₁₀-tag upstream and downstream of the *SacI* and *XbaI* sites, respectively.

Expression of LH2 complexes and determination of optimal IPTG concentration. With conjugation techniques, plasmid pRK*lacI^qpucPpucBHis₁₀AC* was transferred into *Rb. sphaeroides* mutant DD13. When cell cultures of DD13 transconjugants reach OD₆₀₀ of 0.5–0.8, IPTG is added to the growth medium and simultaneously the cell cultures are shifted from aerobic conditions to semi-aerobic conditions. After that, cell cultures of DD13 transconjugants are scanned at the band of 700–900 nm. Two spectral peaks appear at ~800 and ~850 nm, suggesting the production of LH2 complexes, and the spectra are scaled to reflect the level of LH2 complexes per amount of cell cultures, as shown in Fig. 2. The degree of induction is controlled by varying the concentration of IPTG. Growth without IPTG allowed no background expression (Fig. 2d), while growth with concentrations of IPTG at 0.1 and 0.5 mM resulted in low-level production of LH2 complexes (Fig. 2, a and b). In contrast, IPTG at the concentrations of 0.8, 1.0, and 1.5 mM was sufficient to activate the hybrid promoter and consequently yield high level production of LH2 complexes (Fig. 2, c, e, and f), and 1.0 mM is considered as the optimal concentration in subsequent studies.

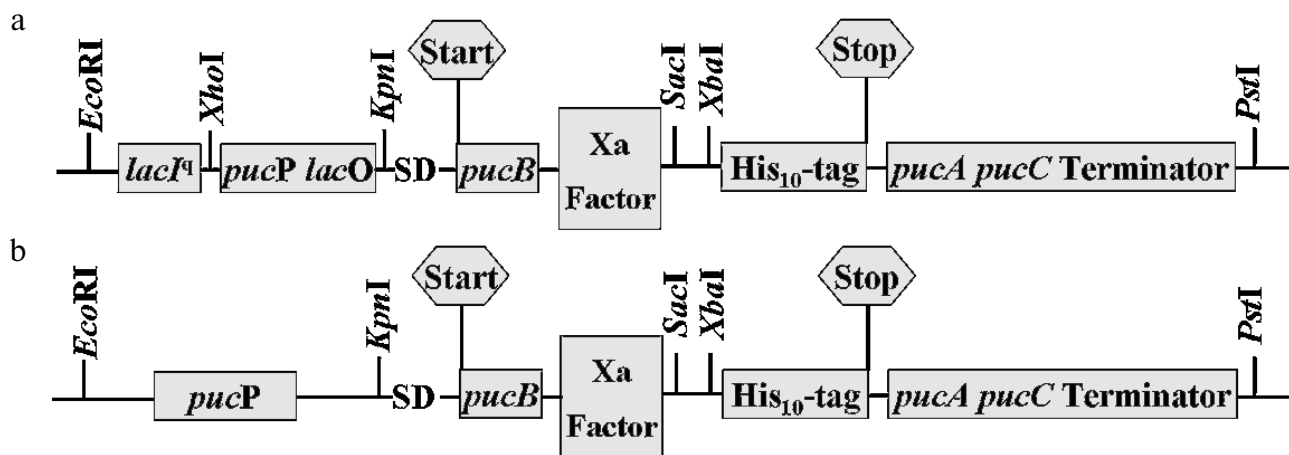

Fig. 1. Schematic representation of the expression vector constructs. a) The plasmid pRK*lacI^qpucPpucBHis₁₀AC* contains the hybrid promoter comprised of *E. coli lacI^q* and *lacO*, *pucP* promoter of *Rb. sphaeroides* and structural genes *pucB* and *pucA* encoding β - and α -polypeptide of LH2 complex. b) Plasmid pRK*pucPpucBHis₁₀AC* lacking the *E. coli lacI^q* and *lacO* covers the same structure compared to that of the pRK*lacI^qpucPpucBHis₁₀AC*. Start and Stop represents start codon and stop codon, respectively.

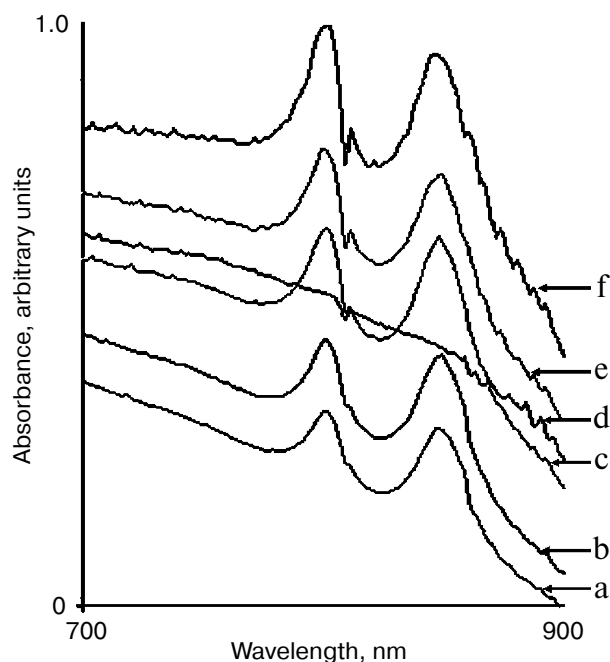

Fig. 2. Spectral properties of DD13/pRKlac^{puc}PpucBHis₁₀AC cell cultures after adding IPTG to the growth medium. Low concentrations of IPTG (0.1 mM (a), 0.5 mM (b)) cannot completely activate the hybrid promoter, while high concentrations of IPTG (0.8 mM (c), 1.0 mM (e), 1.5 mM (f)) probably activate the hybrid promoter completely. Growth without IPTG (0 mM (d)) allowed no background expression.

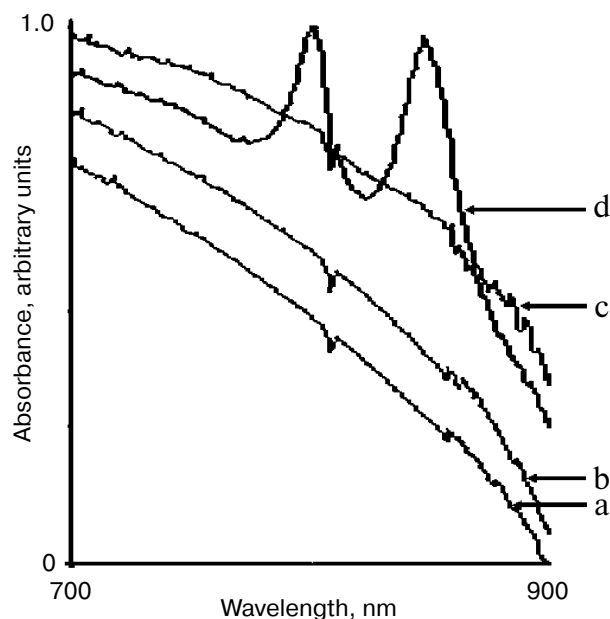

Fig. 3. Spectral absorbance of DD13/pRKlac^{puc}PpucBHis₁₀AC (a, b) and DD13/pRKpucPpucBHis₁₀AC (c, d). a, b) Absorbance of DD13/pRKlac^{puc}PpucBHis₁₀AC grown under semi-aerobic conditions in the absence of IPTG (a) and under aerobic conditions in the presence of IPTG (b). c, d) Absorbance of DD13/pRKpucPpucBHis₁₀AC grown under aerobic conditions in the absence of IPTG (c) and under semi-aerobic conditions in the presence of IPTG (d).

Because the hybrid promoter we constructed allows a dual regulation by both IPTG and low oxygen level, only meeting the two requirements can result in the production of LH2 complexes. Clearly, there is no background synthesis of LH2 complexes under uninduced conditions (without IPTG) even for cells grown under semi-aerobic conditions, as shown in Figs. 2d and 3a. Similarly, no LH2 complexes were produced when cells grown under aerobic conditions even in the presence of IPTG, as shown in Fig. 3b. Cell cultures of DD13/pRKpucPpucBHis₁₀AC showed similar spectral properties compared to that of DD13/pRKlac^{puc}PpucBHis₁₀AC, as revealed in Fig. 3c.

Purification and identification of the expressed protein. To further test our strategy, we purified the expressed protein from *Rb. sphaeroides* DD13 transconjugants by Ni-IDA. The resulting purified protein was examined by SDS-PAGE, and a band of approximately 10 kDa was observed on Coomassie Brilliant Blue-stained 15-20% SDS-polyacrylamide gradient gel, as revealed in Fig. 4. Western blot analysis was performed using anti-His antibody. As shown in Fig. 5, a band of approximately 10 kDa was observed on PVDF membrane. All this reliable evidence suggested the hybrid promoter we constructed was efficient to tightly regulate the

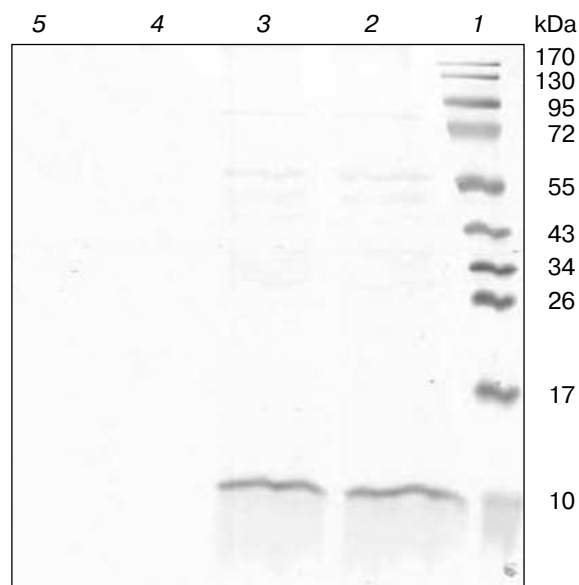

Fig. 4. SDS-PAGE analysis of purified proteins. Lanes: 1) molecular weight markers; 2) protein purified from DD13/pRKlac^{puc}PpucBHis₁₀AC with IPTG induction; 3) protein purified from DD13/pRKpucPpucBHis₁₀AC; 4) sample purified from DD13 as control; 5) sample purified from DD13/pRKlac^{puc}PpucBHis₁₀AC without IPTG induction.

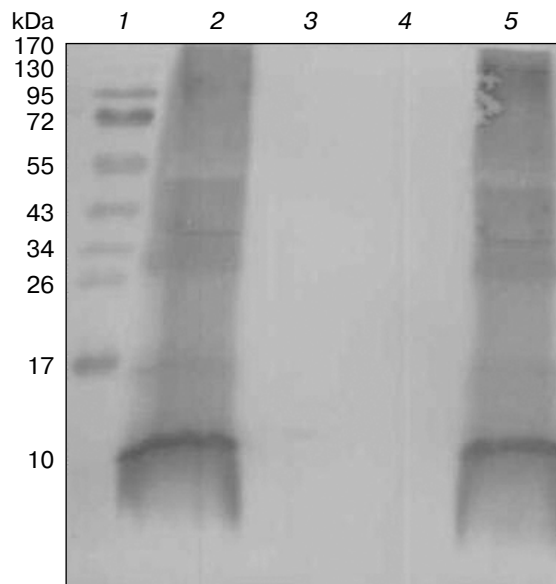

Fig. 5. Western blot analysis of purified proteins. Lanes: 1) molecular weight markers; 2) protein purified from DD13/pRK*lacI^qpucPpucB*His₁₀AC with IPTG induction; 3) sample purified from DD13/pRK*lacI^qpucPpucB*His₁₀AC without IPTG induction; 4) sample purified from DD13 as control; 5) protein purified from DD13/pRK*pucPpucB*His₁₀AC.

expression of target genes, and our strategy actually worked well.

DISCUSSION

It is well known that the *lac* operon plays important roles in the development of molecular and systems biology [21], and it displays much of the complexity and subtlety inherent in gene regulation, including transcription, translation, protein assembly, protein degradation, binding of different proteins to DNA, and binding of small molecules to DNA-binding proteins [22]. The *lac* operon consists of a regulatory domain and three structural genes with related functions required for the uptake and catabolism of lactose. A regulatory protein, the LacI repressor, is a homotetramer comprised of two functional homodimers [23, 24], and it is one of the best-studied prokaryotic transcriptional regulatory proteins [25]. It can bind to *lacO* and prevent the RNA polymerase from transcribing the three structural genes. The gene *lacI^q* is a mutant *lacI* that produces 10-fold more repressor than *lacI* is often used in recombinant strains to provide better repression of recombinant gene expression in the absence of inducer [26]. Induction of the *lac* operon occurs only when the inducer molecule binds to the repressor, and the inducers that can be used include allo-lactose, a metabolic product of lactose and gratuitous inducers, such as IPTG or methyl- β -D-thiogalactoside, and we selected IPTG to derepress the

negative regulation of LacI^q repressor in this study. The probability for the inducer to bind to the repressor depends on the inducer concentration inside the cell. The *puc* operon of *Rb. sphaeroides* is composed of the *pucP* promoter and *pucBA* genes encoding the β - and α -polypeptides of the LH2 complex, respectively. Additional downstream open reading frame(s) are present that encode gene product(s) involved in the posttranscriptional control of expression and assembly of the β - and α -polypeptides to form the LH2 complexes [27].

In this study, we have successfully constructed LH2 polypeptide expression vector carrying a hybrid promoter comprised of *lacI^q* and *lacO* of *E. coli* JM109 and *puc* operon promoter *pucP* of *Rb. sphaeroides*. Spectral properties, SDS-PAGE, and Western blot analysis indicate that the hybrid promoter actually works well. The *puc* operon promoter *pucP* can be greatly repressed by high oxygen level. Despite the negative regulation by high oxygen tension, IPTG plays a crucial role in the production of LH2 complexes. Thus, we can get the spectral properties of cultures of *Rb. sphaeroides* DD13 transconjugants grown under semi-aerobic conditions after adding IPTG. As expected, there is no background expression of LH2 complexes without IPTG even under semi-aerobic conditions, as shown in Fig. 3a. Similarly, we cannot obtain spectral properties of cultures grown under aerobic conditions even after adding IPTG (Fig. 3b).

In addition, there is no background expression without IPTG in *Rb. sphaeroides* DD13 transconjugants. This property can be used to overexpress proteins that are lethal to the cells. On the other hand, in cell cultures of transconjugants, two absorption bands can be observed at \sim 800 and \sim 850 nm after induction, which can be used as the marker for harvest of the cells. With the His₁₀-tag in the C-terminus of *pucB*, the recombinant proteins can be purified by the affinity tag and identified by Western blot. Actually, the His₁₀-tag can also be fused at the C-terminus of *pucA*, which will achieve the same goal. It is worth being determined that if there is an expected band in the Western blot, the Xa factor can be used to cut off *pucB* encoding protein to obtain more highly purified target proteins. The next step is to utilize the LH2 expression vector bearing the hybrid promoter to express recombinant proteins using *Rb. sphaeroides* as a novel host.

We thank Prof. C. Neil Hunter for the DD13 strain.

This work was supported by the program "863" of the Ministry of Science and Technology of the People's Republic of China (No:2006AA02Z138) and National Natural Science Foundation of China (No:30771463, 30871709).

REFERENCES

1. Naylor, G. W., Addlesee, H. A., Gibson, L. C. D., and Hunter, C. N. (1999) *Photosynth. Res.*, **62**, 121-139.

2. Kiley, P. J., and Kaplan, S. (1988) *Microbiol. Rev.*, **52**, 50-69.
3. Woese, C. R., Stackebrandt, E., Weisburg, W. G., Paster, B. J., Madigan, M. T., Fowler, V. J., Hahn, C. M., Blanz, P., Gupta, R., Nealson, K. H., and Fox, G. E. (1984) *Syst. Appl. Microbiol.*, **5**, 315-326.
4. Boonstra, A. F., Visschers, R. W., Calkoen, F., van Grondelle, R., van Bruggen, E. F. J., and Boekema, E. J. (1993) *Biochim. Biophys. Acta*, **1142**, 181-188.
5. Zeilstra-Ryalls, J., Gomelsky, M., Eraso, J. M., Yeliseev, A., O'Gara, J., and Kaplan, S. (1998) *J. Bacteriol.*, **180**, 2801-2809.
6. Hu, X., Ritz, T., Damjanovic, A., and Autenrieth, F. (2002) *Q. Rev. Biophys.*, **35**, 1-62.
7. Walz, T., Jamieson, S. J., Bowers, C. M., Bullough, P. A., and Hunter, C. N. (1998) *J. Mol. Biol.*, **282**, 833-845.
8. Savage, H., Cyrklaff, M., Montoya, G., Kuhlbrandt, W., and Sinning, I. (1996) *Structure*, **4**, 243-252.
9. Klinekofort, W., Germeroth, L., van den Borek, J. A., Schubert, D., and Michel, H. (1992) *Biochim. Biophys. Acta*, **1140**, 102-104.
10. Koepke, J., Hu, X., Muenke, C., Schulten, K., and Michel, H. (1996) *Structure*, **4**, 581-597.
11. Pemberton, J. M., Horne, I. M., and McEwan, A. G. (1998) *Microbiology*, **144**, 267-278.
12. Khan, S. R., Gaines, J., Roop, R. M., 2nd., and Farrand, S. K. (2008) *Appl. Environ. Microbiol.*, **74**, 5053-5062.
13. Oh, J. I., and Kaplan, S. (2000) *EMBO J.*, **19**, 4237-4247.
14. Mardanov, A. V., Strakhova, T. S., Smagin, V. A., and Ravin, N. V. (2007) *Gene*, **395**, 15-21.
15. Jones, M. R., Fowler, G. J., Gibson, L. C., Grief, G. G., Olsen, J. D., Crielaard, W., and Hunter, C. N. (1992) *Mol. Microbiol.*, **6**, 1173-1184.
16. Eraso, J. M., and Kaplan, S. (1994) *J. Bacteriol.*, **176**, 32-43.
17. Simon, R., Priefer, U., and Puhler, A. (1983) *Biotechnology (NY)*, **1**, 784-791.
18. Yanisch-Perron, C., Vieira, J., and Messing, J. (1985) *Gene*, **33**, 103-119.
19. Keen, N. T., Tamaki, S., Kobavashi, D., and Trollinger, D. (1988) *Gene*, **70**, 191-197.
20. Hunter, C. N., and Turner, G. (1988) *J. Gen. Microbiol.*, **134**, 1471-1480.
21. Santillan, M., and Mackey, M. C. (2008) *J. R. Soc. Interface*, **5**, S29-S39.
22. Vilar, J. M., Guet, C. C., and Leibler, S. (2008) *J. Cell Biol.*, **161**, 471-476.
23. Lewis, M. (2005) *C. R. Biol.*, **328**, 521-548.
24. Wilson, C. J., Zhan, H., Swint-Kruse, L., and Matthews, K. S. (2008) *Cell. Mol. Life Sci.*, **64**, 3-16.
25. Lakshmi, O. S., and Rao, N. M. (2009) *Protein Eng. Des. Sel.*, **22**, 53-58.
26. Donovan, R. S., Robinson, C. W., and Glick, B. R. (1996) *J. Ind. Microbiol.*, **16**, 145-154.
27. Lee, J. K., Kiley, P. J., and Kaplan, S. (1989) *J. Bacteriol.*, **171**, 3391-3405.